

Application Number: F/YR12/0368/F

Minor

Parish/Ward: Chatteris Town Council/Wenneye Chatteris

Date Received: 14 May 2012

Expiry Date: 9 July 2012

Applicant: Mr. C.S. and A.R. Allen

Agent: Mr. Magnus Gallie – AAH Planning Consultants

Proposal: Erection of 2 x 50 metre high (hub height) wind turbines

Location: Land South West of Old Halves Farm, Chatteris Road, Somersham

Site Area/Density: 00.04ha

Reason before Committee: This application is before the Planning Committee as it is in the wider interest.

1. EXECUTIVE SUMMARY/RECOMMENDATION

In planning policy terms the proposal is considered to accord with national, regional and local planning policy in contributing to the need for renewable energy without adversely affecting design, access, shadow flicker and noise. However, the proposed turbine is located in an area where the cumulative landscape, visual and sequential impacts are considered to be determining issues together with heritage and cumulative biodiversity issues. The proposal is, therefore, considered to have adverse cumulative landscape, visual and sequential impacts but on balance acceptable heritage and cumulative biodiversity issues. These issues have been evaluated against the requirements to contribute to regional and national targets for renewable energy generation and the benefits of reducing carbon consumption but are, on balance, sufficient reason to resist this proposal.

2. HISTORY

Of relevance to this proposal is:

Red Tile Wind Farm approximately 4 km to the north west of the site.

3. PLANNING POLICIES

3.1 National Planning Policy Framework:

Paragraph 2: Planning law requires that applications for planning permission must be determined in accordance with the development plan.

Paragraph 14: Presumption in favour of sustainable development.

Paragraph 93: Meeting the challenge of climate change, flooding and coastal change.

Paragraph 109: Conserving and enhancing the natural environment.

Paragraph 98: Need for renewable energy and acceptable impacts.

3.2 Draft Fenland Core Strategy July 2012:

CS12: Responding to climate change and managing the risk of flooding in Fenland.

CS14: Delivering and Protecting High Quality Environments across the District.

3.3 Fenland District Wide Local Plan:

EMP1: Proposals will normally be favoured for new, or the extension or expansion of existing firms ... outside DABs the expansion of existing firms will only be permitted where certain criteria are satisfied.

E1: To resist development likely to detract from the Fenland landscape. New development should meet certain criteria.

E8: Proposals for new development should: allow for protection of site features, be of a design compatible with their surroundings, have regard to amenities of adjoining properties and provide adequate access.

E20: To resist any development which by its nature gives rise to unacceptable levels of noise, nuisance and other environmental pollution.

E3: To retain existing trees and hedgerows. To impose, where appropriate, conditions on planning applications requiring landscaping and tree planting schemes. To request the submission of a landscaping scheme with planning applications on visually important sites.

3.4 East of England Plan:

ENG2: The development of new facilities for renewable power generation should be supported with the aim that by 2010 10% of the region's energy, and by 2020 - 17%, should come from renewable sources (excluding energy from offshore wind).

ENV2: Planning Authorities should protect and enhance the diversity and local distinctiveness of countryside character by developing area-wide strategies and landscape character assessments to ensure development respects/enhances local landscape character.

The ENV3: Ensure that new development minimises damage to biodiversity.

Policy ENV4: Ensures that the landscape, historic and wildlife value of farmland is increased whilst responding to issues such as climate change.

ENG1: Carbon dioxide emissions and energy performance.

SS1: Achieving sustainable development.

3.5 The Fenland Wind Turbine Development Policy Guidance June 2009 (WTDPG):

Details contained under assessment section.

3.6 Wind Turbines and Sensitive Bird Populations : Spatial Planning for Wind Turbines in the Fens Natural Area:

Within Zone 2 SW Ouse Washes – No formal Nature Conservation designation. Sensitive species are Bewick's and Whooper swans, collision risk medium, disturbance medium. Sensitive bird populations present – early consultation/assessment required. Cumulative impact may result in significant effect and will require assessment.

4. CONSULTATIONS

4.1 Chatteris Town Council:

Recommend refusal. There are already sufficient wind turbines in Fenland and the immediate area and Chatteris Town Council is not in favour of anymore.

4.2 **Local Highway Authority (CCC):**

Thank you for the additional information relating to the abnormal load routeing and the measures and works that have been identified along that route within Cambridgeshire to accommodate the loads.

Prior to commencement of any development, the applicant must contact the relevant Area Maintenance team to agree the measures and works required to accommodate the loads within Cambridgeshire.

Prior to any works to the existing access to Chatteris Road, full details of the temporary widening of the site access must be submitted to CCC for approval and be the subject of a Short Form Agreement with CCC. It is an offence to carry out any works within the public highway without the permission of the Highway Authority.

4.3 **Natural England:**

Based on the information provided, we have no objection to this application.

Designated Sites

The nearest European or nationally designated site is the Ouse Washes SSSI, SPA, SAC, Ramsar, located approximately 4.2km west of the proposed turbine location at its nearest point. Natural England advises that at this distance the proposal is unlikely to have any impact on the qualifying species of any designated sites associated with the Ouse Washes.

Protected Species

We are satisfied that the proposed turbines will be located at a sufficient distance from any potential bat roosts or other features and therefore consider that bats are unlikely to be adversely affected by this development. The phase 1 habitat survey has followed the correct methodology and all European protected and BAP species have been well considered.

We therefore consider that protected species are unlikely to be affected by this development.

Biodiversity Enhancements

This application may provide opportunities to incorporate new habitats within the wider landholding, or improve the management of existing farmland habitats for the benefit of wildlife. For further information on such opportunities see for example the following HGCA guidance. Section 40 of the Natural Environment and Rural Communities Act (2006) states that *'Every public authority must, in exercising its functions, have regard, so far as is consistent with the proper exercise of those functions, to the purpose of conserving biodiversity'*. Section 40(3) of the same Act also states that *'conserving biodiversity includes, in relation to a living organism or type of habitat, restoring or enhancing a population or habitat'*. Your authority could therefore consider securing measures to enhance the biodiversity of the wider site from the applicant as part of the development.

Landscape and Visual Impact

The proposal site is not located within, or in proximity to a protected landscape (National Park or Area of Outstanding Natural Beauty), and Natural England would not therefore look to provide any detailed comments regarding landscape and visual impacts.

- 4.4 **Middle Level Commissioners:** Based on the evidence submitted, it would appear that the current turbine layout does not detrimentally affect the Boards system. Various consents required – advice given.
- 4.5 **Cambridgeshire Architectural Liaison Officer:** No objection- advice offered.
- 4.6 **CAA:** Advice offered.

- 4.7 **Sutton Meadow Airfield:** The proposed Turbines will have a detrimental effect on the operation of Sutton Meadows Airfield by creating a safety hazard within the area used for local flying and flying training that is currently free of obstructions and constraints. On this occasion the effect of the development is not so substantial that we wish to object, However any closer or taller structures may have a severe effect on airfield operations. We would be grateful therefore to be included on the list of local issues and consultees for any similar future pre application enquires or planning applications.
- 4.8 **Chatteris Airfield:** No objection.
- 4.9 **Joint Radio Company:** Do not foresee any potential problems based on known interference scenarios.
- 4.10 **Environment Agency** No objection – advice offered.
- 4.11 **NERL Safeguarding Office:** Does not conflict with our safeguarding criteria.
- 4.12 **Anglian Water:** No concerns from a groundwater perspective.
- 4.13 **Local Residents/Interested Parties:** 3 letters of objection from 5 individuals
 Concern for the unique feature of the Fenland landscape,
 There are already many wind turbines close by in this area and more will detract from the wide open skies and beauty of the area,
 Once planning permission has been granted for 2 turbines then more will be accepted,
 We hope Fenland Council will be protective of this area, and if necessary space out wind farms rather than create a ‘wind farm city’ in this lovely countryside,
 Proposed turbines are too close to residential dwellings ranging from 594 m to 700 m away,
 There will be noise, flicker and the associated health problems,

Horse riding takes place in the surrounding countryside,
Due to the flat, exposed landscape of the Fenland, the turbines will dominate views from every direction,
There is already another wind farm which is clearly visible from this area,

It is of concern that wildlife may be affected, injured or disturbed by the turbines,

Property values will be affected,

The road is bad enough so being distracted by wind turbines could cause hazard,

Like the idea of turbines but off shore not in the countryside.

1 letter of support

Clean, environmentally friendly and I think they look elegant.

4.14 **MOD (Defence Infrastructure Organisation) Safeguarding Officer:** No objections

4.15 **Environmental Health**

We recommend that the following conditions should be added to a planning permission should it be granted.

Night-time noise levels

The noise emission (LA90, 10 minute) from effects of the wind turbine, as measured in free field conditions at any dwelling, shall not exceed during night hours 2300 – 0700, the greater of 43dB(A) or 5dB(A) above the night hours background noise (LA90, 10 minute) as measured in accordance with ETSU-R-97.

Day-time noise levels

At all other times the noise emission (LA90, 10 minute) from the effects of the wind turbine, as measured in free field conditions at any dwelling, shall not exceed the greater of 38dB(A) or 5dB(A) above the Quiet Waking Hours background noise (LA90, 10 minute) at wind speeds within the site not exceeding 10 metres per second.

Informative:

Period of hours have been used are as defined in ETSU-R-97 (The

Assessment and Rating of Noise from Wind Farms).

Quiet day-time periods are defined as:

All evenings from 6pm to 11pm, Plus Saturday afternoons from 1pm to 6pm, Plus all day Sunday, 7am to 6pm. Night-time is defined as 11pm to 7am

Remedial Action

In the event that noise exceeds the limits specified in the planning permission remedial action must be undertaken to reduce the noise levels. This would include, checking the source noise level of individual turbines (if this has not already occurred as part of any warranty agreement with the turbine supplier or by compliance testing). Mitigation applied may involve slowing of turbine rotational speed, thus reducing noise, or even shut-down of individual turbines, under critical wind conditions.

Operator monitoring

At the reasonable request of, and following a complaint to, Fenland District Council the operator of the development shall, measure and assess the level of noise emissions from the wind turbine generators, following the procedures described in "The Assessment and Rating of Noise from Wind Farms, ETSU-R-97" published by ETSU for the Department of Trade and Industry.

Cumulative impact

Monitoring undertaken to identify compliance of planning conditions or justify complaints must consider the cumulative impact of other wind farms. The existence of other wind farm noise should not be considered as part of the prevailing background noise.

4.16 *English Heritage*

I am concerned by the level of information provided in the addendum report. It is not of a good standard, the archaeological sites in question do not appear to have been visited and it is not clear

that a Historic Environment specialist has been involved in assessing the impacts to the archaeological sites. In addition there are no photographs of, or from the designed assets in question, and there is no assessment of current land use, hence my concern that the assets have not been valued. I feel the applicant should make all reasonable efforts to visit the sites and the lack of public access is not an acceptable reason for not assessing impacts effectively. It is therefore difficult to verify the claims made in paragraph 2.5 about the setting (ref AAH/2404/12PLA page 6), and I would challenge the statement that the sites presence in the landscape is entirely below ground. The setting is likely to include a wider and more extensive experience of the landscape. I would also disagree with the assessment of harm.

This application in my view falls short of the requirements necessary to fulfil paragraph 128 of the NPPF. That said it is relatively clear that although there is clearly change to the setting of the assets and that this change constitutes a degree of harm, this harm is not substantial. If the Local Authority are happy to accept the application, given its short comings then we would accept that paragraph 134 of the NPPF would be appropriate. In particular that 'where a development proposal will lead to less than substantial harm to the significance of a designated heritage asset, this harm should be weighed against the public benefits of the proposal...'. The Local Planning authority would be free to weigh the harm to the setting of the heritage assets against the benefits of the scheme in accordance with their policies.

4.17 *Huntingdonshire (Planning)*

This Council does not support or raise objection to the application and highlight issues that will need to be

addressed irrespective of the Council boundaries.

- 4.18 **Section 106 Officer** As this development falls below 5kw no S106 agreement is being sought.
- 4.19 **Peterborough Airfield Manager** No objection.

5. **SITE DESCRIPTION**

- 5.1 The application site is situated on agricultural land at Old Halves Farm, approximately 3.5 km north east of Somersham and approximately 3 km south of Chatteris in typically flat, open Fenland countryside. The site is at the extreme south of Fenland District in a 'wedge' of land bounded by Huntingdon District to the west and East Cambridgeshire District to the east. The site is accessed via a farm track which connects with the B1050 to the west of the site. The area is relatively clear of structures on the skyline with the exception of the Red Tile Wind Farm, which dominates the landscape approximately 4 km to the north west. The area is characterised by sporadic residential and farm buildings. The nearest residential properties are situated at a distance ranging from approximately 541 to 804 metres. The principal nearest listed structures are 3.53, 4, and 5.8 km distant. The turbines are also located at a distance of approximately 3.5 and 3.2 km from 3 scheduled monuments – the remains of 2 Bronze Age round barrows and a Neolithic enclosure.

6. **PLANNING ASSESSMENT**

6.1 **Nature of Application**

The application seeks full planning permission for the erection of 2 x 3 bladed wind turbine assemblies with an overall height of 74 metres to the top blade tip. The proposal is not centred on a particular turbine choice as models and turbine designs are constantly changing, but the turbine would meet the specifications provided. Access will be via an existing farm track which runs directly from the B1050. A full Environmental Impact Assessment was not required for this application, but in addition to the plans and supporting information, the application has been accompanied by a number of documents including noise measurement criteria, landscape and visual impact assessment, biodiversity study, flood risk assessment, heritage statement and design and access statement.

The application is considered to raise the following key issues;

- Site History
- Principle and policy implications
- Landscape and Visual Impact Assessment
- Biodiversity
- Heritage
- Design
- Access
- Contributions.

It is considered that, by assessing the above issues, it should be determined whether any adverse effects might outweigh the positive benefits of a

renewable energy project.

Site History

There is no immediate site history but turbines have been erected at the Red Tile Wind Farm site, which dominates the landscape approximately 4 km to the north west within Huntingdon District. This development requires to be considered in context with the proposal.

Principle and Policy Implications

The proposal has been considered in line with National Guidance in the form of the new National Planning Policy Framework (NPPF), Development Plan Policy in the form of the Fenland District-Wide Local Plan 1993, the East of England Plan and the new Fenland Communities Development Plan Draft Core Strategy July 2012, and other guidance all of which are listed in the relevant section of this report.

The Government has set a target of generating 20% of the UK's electricity by 2020 and also aims for the UK to be on a path to cut its carbon dioxide emissions by 60% by 2050, as well as maintaining reliable and competitive energy supplies. The development of renewable energy is considered to form a key part of meeting this target, which has led to the view that renewable energy schemes should be supported where they do not result in other adverse impact upon the area that outweigh the renewable energy benefits. This application is for the erection of 2 wind turbines and associated infrastructure. Wind turbines are a sustainable and efficient source of renewable energy and, therefore, generally comply with the provisions of the NPPF and emerging Core Strategy regarding renewable energy benefits.

The Fenland Wind Turbine Development Policy Guidance June 2009 (WTDPG)

This document provides detailed local guidance particularly targeted at wind turbine development. It is recognised that there is a need to ensure that future development is in balance with the local landscape and the population that lives within it. As a result the Wind Turbine Development Policy Guidance (WTDPG) was produced by landscape consultants for FDC in June 2009. The WTDPG has been adopted as Supplementary Planning Guidance by the Council. The WTDPG sets down a number of landscape character types and then sets out criteria for evaluating the sensitivity of each type.

Section 6 sets out the criteria for assessing planning applications based on:

- *Landscape character*
- *Landscape capacity*
- *Visual impacts*
- *Cumulative landscape impacts*
- *Cumulative visual impacts*
- *Biodiversity considerations*
- *Heritage considerations*
- *Recreation and transport routes*
- *Mitigation*
- *Guidance on Form and Siting*

Where wind turbine development is considered appropriate in the light of the above criteria, guidance is then given in terms of how the form and siting of turbine(s) should relate to the characteristics of the landscape type in which it is

to be situated. Under the above guidance the proposed site is situated within the following designations:

- 1 *“The Fens” landscape character area which has a medium - high landscape capacity for groups of 17+,*
- 2 *A high landscape capacity for single turbines*
- 3 *A high landscape capacity for small turbine groups (2-5),*
- 4 *A high landscape capacity for small/medium turbine groups (6-10),*
- 5 *A medium-high landscape capacity for medium turbine groups (12-16),*
- 6 *A medium-high landscape capacity for large turbine groups (17+),*
- 7 *Within the 5km conspicuous zones for existing turbines,*
- 8 *Immediately south of the Chatteris Clay Island.*

In terms of landscape capacity within the Drained Fenland character type the WTDPG advises that the “cumulative impact of wind turbine development needs to be carefully considered”.

In terms of visual impact the WTDPG advises that:

- *Proposals within 400m of a settlement are highly unlikely to be considered acceptable in visual amenity terms.*
- *There should be no shadow flicker for any residential properties or on A or B roads.*
- *Proposals within 2km of a settlement should be carefully considered as turbines are likely to be highly prominent features*
- *Turbines should be set back a minimum distance of 200m from public footpath. The WTDPG advises that for National Trails this should be 3 times the distance of the overall height of the turbine.*
- *Residential properties and users of recreational routes/facilities are likely to be considered more sensitive as receptors.*

In terms of cumulative landscape impact the WTDPG advises that that there is a danger that excessive development of wind turbines in any landscape would at some point result in such material change as to unbalance and overpower the existing key characteristics of the landscape. To prevent this it advises that within the Drained Fenland character type not more than 25% of the area should be within 2km of a turbine development (prominent zone) and not more than 75% within 5km (conspicuous zone).

- *Proposals for new wind turbine development, detached from existing turbine sites by more than 500m but within 4km of existing turbine developments are unlikely to be acceptable in visual terms. In some circumstances a distance greater than 500m is required.*
- *Proposals for new development within 10km of existing turbine developments need to be carefully considered.*
- *Settlements of more than 10 dwellings should not have wind turbines in more than 90° of their field of view from public or residential viewpoints within or around the settlements from a distance of 10km from the settlement.*
- *No more than 25% of the length of A and B roads and railways should be within 2km of wind turbines (prominent zone) and no more than 75% of its length being within 5km of turbines (conspicuous zone)*
- *Turbines within 4km of each other are likely to demonstrate a significant cumulative impact from a number of locations and are less likely to be*

considered acceptable in visual/landscape terms, unless they form a relatively modest extension to an existing turbine development.

Landscape and Visual Impact Assessment

The site is not located within any national or locally designated landscape areas but it is important to consider the impact of the turbine on the overall appearance of the Fenland landscape. Landscape and visual impact must, therefore, also be considered in relation to existing and proposed turbines in the area.

The WTDPG seeks to set an appropriate framework to assess emerging proposals and applications but specifically as stated in para 6.2:-

'Non-compliance with an individual criterion should not necessarily preclude turbine development. All the environmental factors should be carefully evaluated and then balanced by the planning authority against the requirements to contribute to regional and national targets for renewable energy generation and the benefits of reducing carbon consumption. The guidelines should also always be considered in conjunction with a detailed study of the site and its surroundings, particularly in terms of existing trees, hedges, buildings and structures that may provide visual mitigation of a wind turbine development'

The Red Tile Wind Farm, which dominates the landscape approximately 4 km to the west, has a major impact in the landscape of this area and requires to be considered in the context of the proposal.

Cumulative Landscape Effects

Whilst proximity to existing turbine locations can be seen as an effective way to reduce cumulative landscape effects, this is only one aspect of the WTDPG in relation to cumulative landscape impacts. The proposed turbines at Old Halves Farm are approximately 4 km from the Red Tile wind farm to the north west, which already dominates the landscape of this area. Turbines within 4km of each other are likely to demonstrate a significant cumulative impact from a number of locations and are less likely to be considered acceptable in visual/landscape terms, unless they form a relatively modest extension to an existing turbine development. The proposal would add to the cumulative impact of turbines in the area and encourage further development to the detriment of the open Fenland landscape setting.

Cumulative Visual Effects

The 'Wind Turbine Development Policy Guidance' report considers that small groups of turbines can work well as focal points and landmarks. However, the relationship with other groups in the locality needs careful consideration to avoid undesirable conflict by effectively spreading the cumulative visual impact over an extensive area.

The proposed turbines at Old Halves Farm are approximately 4 km from the Red Tile wind farm to the west, which already dominates the landscape of this area. The WTDPG identifies that proposals within 4km of existing turbine developments are unlikely to be acceptable in visual terms.

The WTDPG states that proposals for new wind turbine development should be considered in relation to the visibility of turbine development when experienced from A and B classification roads and railway lines from which the following

conclusions have been drawn.

- 1) The turbines would be located within the 'Drained Fenland' Landscape Character Type, which has high capacity to accommodate small groups of turbines. However, in specific terms the Old Halves Farm Turbines would add to the growing feeling of being within a windfarm landscape by adding a visually unacceptable new dimension in the open Fenland landscape to the east of the B1050 road.
- 2) In cumulative landscape character terms, the addition of turbines at this location would establish an adverse cumulative presence.
- 3) The visual impacts of the proposed turbine would create localised significant effects for residents in surrounding residential properties.

In summary, there are particular concerns over the cumulative visual impacts which would be created.

Sequential Visual Effects

Sequential visual effects can be investigated through considering the potential impact of the proposal in the context of the Red Tile Wind Farm and on key routes through the area. Effects will be clearly visible from the B1050 - particularly the open section between Chatteris and Somersham. Overall, it is considered that the addition of the Turbines will result in a significant adverse change to views from the B1050 through the landscape, and the experience of people using these routes.

Biodiversity

Natural England advises that at this distance the proposal is unlikely to have any impact on the qualifying species of any designated sites associated with the Ouse Washes and that protected species are unlikely to be affected by this development.

Heritage

English Heritage remain concerned by the level of information provided in the addendum report which is considered not of a good standard. The view is taken that the application falls short of the requirements necessary to fulfil Paragraph 128 of the NPPF. Whilst there is clearly change to the setting of the assets and that this change constitutes a degree of harm, this harm is not considered to be substantial. Paragraph 134 states that 'where a development proposal will lead to less than substantial harm to the significance of a designated heritage asset, this harm should be weighed against the public benefits of the proposal'.

Design

Shadow flicker created by the turning of the turbine blades at certain times of day should also be considered. In terms of this proposal the impact is considered to be minimal. Noise impact from the turbine has been assessed and can be controlled by an appropriate planning condition should consent be granted. The turbine is of a standard design, but should permission be forthcoming it would be on the basis of the design submitted as any alteration to that design may require a further submission.

Access

Access into the site will be via the existing farm track. CCC Highways have agreed a way forward for access upgrading and delivery routes should planning permission be granted.

Contributors

Concern has been expressed about the unique feature of the Fenland landscape, proximity of existing turbines close by in this area, landscape character and the precedent that will be created. These are considered to be valid issues, but with regard to the latter point each application must be treated on its merits. Issues of noise and flicker are not considered to be issues of concern in this location and whilst horse riding may take place in the surrounding countryside there are no established bridleways affected. The proximity of an existing wind farm is of concern. No adverse wildlife interests have been identified, but cumulative turbine development is an issue. Property values are not a planning consideration. The turbines will be clearly visible in the locality, particularly from the B1050, and this is a cause of concern in an open Fenland setting.

CONCLUSION

- 7.1 In planning policy terms the proposal is considered to accord with national, regional and local planning policy in contributing to the need for renewable energy without adversely affecting design, access, shadow flicker and noise. However, the proposed turbine is located in an area where the cumulative landscape, visual and sequential impacts are considered to be determining issues together with unresolved heritage and cumulative biodiversity issues. The proposal is, therefore, considered to have adverse cumulative landscape, visual and sequential impacts and unresolved heritage and cumulative biodiversity issues. This has been evaluated against the requirements to contribute to regional and national targets for renewable energy generation and the benefits of reducing carbon consumption but is, on balance, sufficient reason to resist this proposal.

8. RECOMMENDATION

Refuse Planning Permission for the following reasons:

The proposal is contrary to:-

- 1. The Fenland Wind Turbine Development Policy Guidance June 2009 as it is considered to have an adverse cumulative landscape, visual and sequential impact in the area,**
- 2. Paragraph 109 of the National Planning Policy Framework 2012 (NPPF) in that it does not conserve and enhance the surrounding natural environment,**
- 3. Policy CS12 (Renewable energy) and CS14 (Delivering and protecting high quality environments across the District) of the Draft Fenland Core Strategy July 2012.**
- 4. Policies E1 and E8 of the Fenland District Wide Local Plan which seek to resist development likely to detract from the Fenland landscape and have regard to amenities of adjoining properties,**
- 5. Policies ENV2 and 4 of the East of England Plan which seek to protect and enhance the diversity and local distinctiveness of countryside character and ensure development respects/enhances local landscape character.**

9. **UPDATE**

Members will recall that this application was continued from the meeting on 17 October 2012 as a late letter of objection has been received from Cambridge Airport due to potential radar interference and this has been brought to the attention of the applicant who has requested that the application be continued to the next meeting in order to allow discussions to take place between the parties. The Chairman has accepted this request and the application will be continued to the next meeting. This objection has now been withdrawn. The application may, therefore, be determined on the basis of the original report as the report did not make reference to the late objection.

10. **RECOMMENDATION**

Refuse Planning Permission for the following reasons:

The proposal is contrary to:-

- 1. The Fenland Wind Turbine Development Policy Guidance June 2009 as it is considered to have an adverse cumulative landscape, visual and sequential impact in the area,**
- 2. Paragraph 109 of the National Planning Policy Framework 2012 (NPPF) in that it does not conserve and enhance the surrounding natural environment,**
- 3. Policy CS12 (Renewable energy) and CS14 (Delivering and protecting high quality environments across the District) of the Draft Fenland Core Strategy July 2012.**
- 4. Policies E1 and E8 of the Fenland District Wide Local Plan which seek to resist development likely to detract from the Fenland landscape and have regard to amenities of adjoining properties,**
- 5. Policies ENV2 and 4 of the East of England Plan which seek to protect and enhance the diversity and local distinctiveness of countryside character and ensure development respects/enhances local landscape character.**

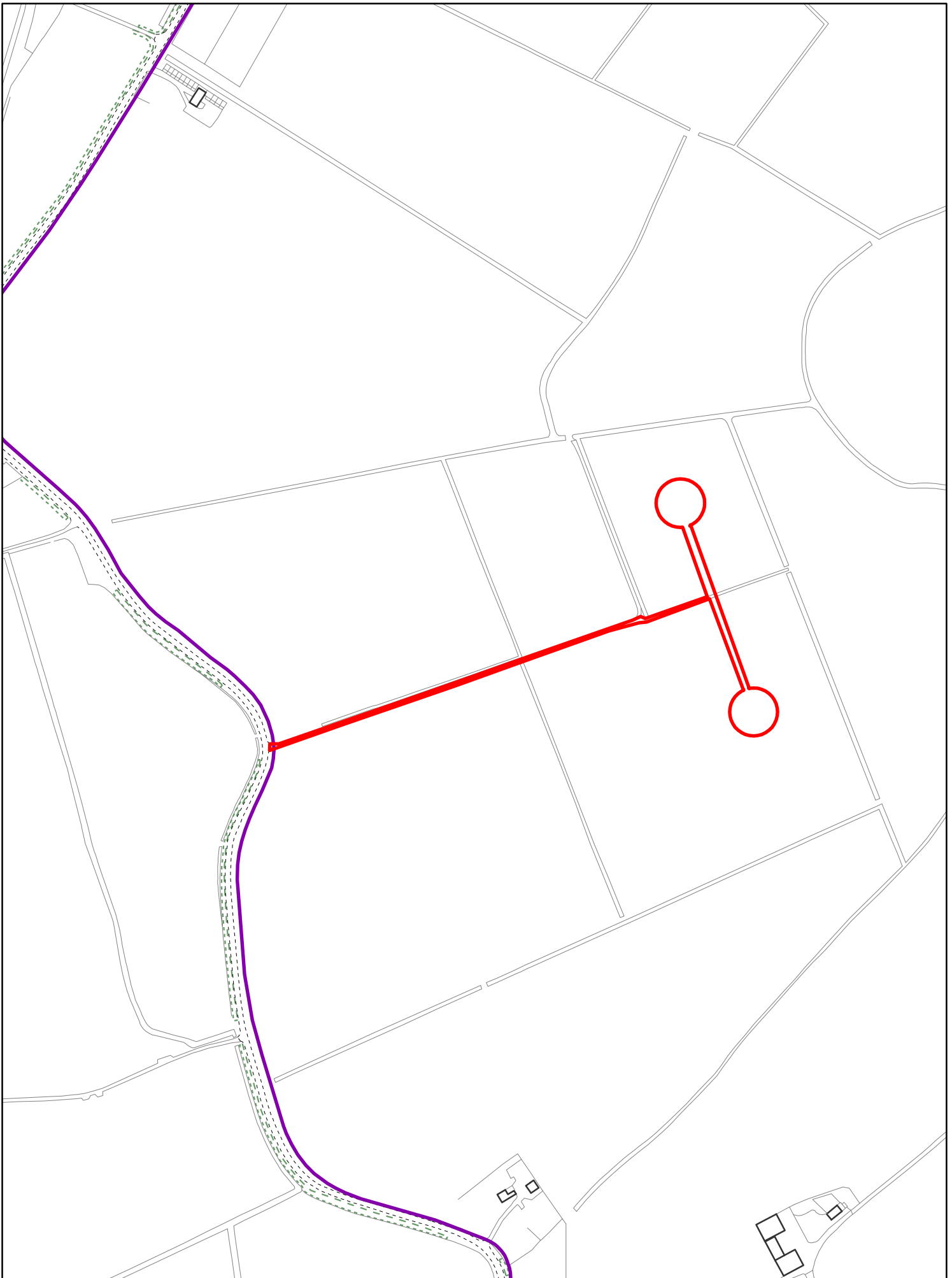

Created on: 17/05/2012

F/YR12/0368/F

© Crown Copyright and database rights 2012 Ordnance Survey 10023778

Scale = 1:5,000



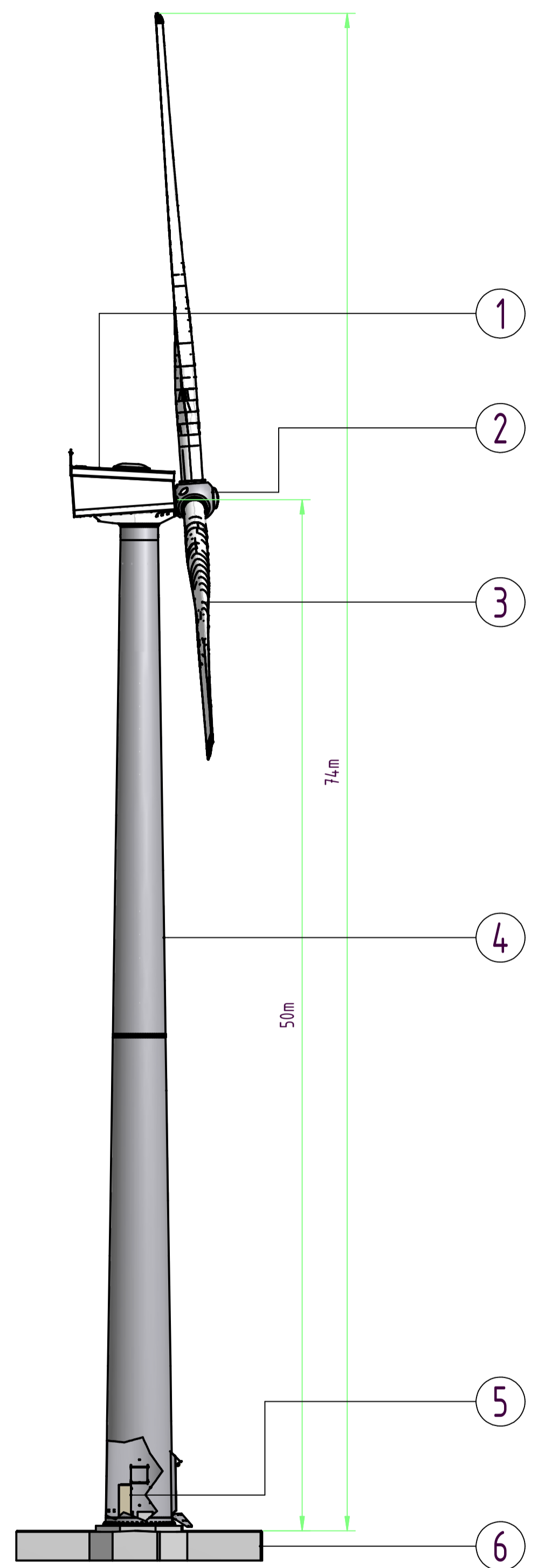
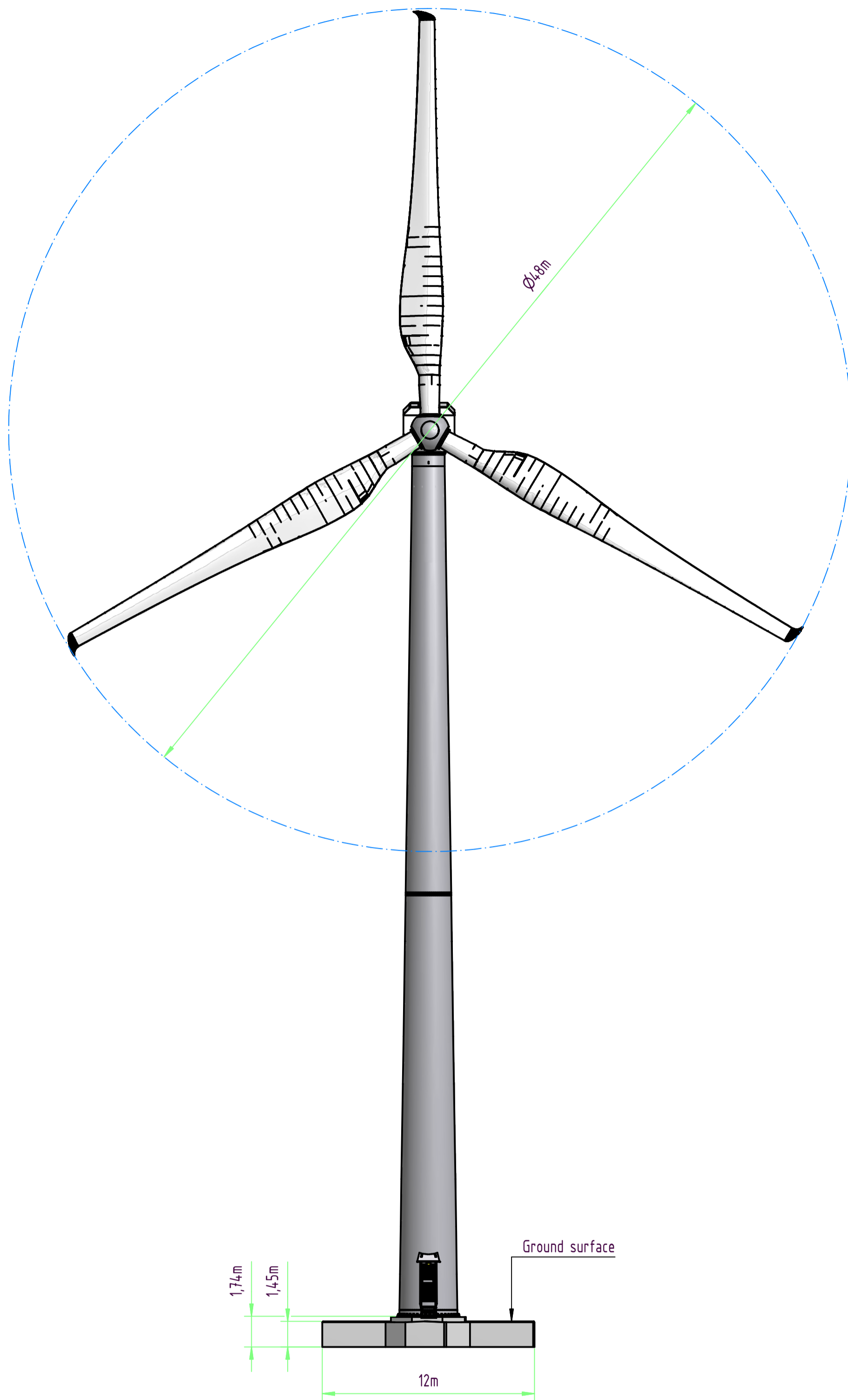

6	1	Foundation Tubular Tower 50m	648-70-0000	
5	1	Electric components	648-40-0000	
4	1	Tubular tower 50m	648-50-0000	
3	3	Blade	648-30-0000	
2	1	Rotor, complete	648-20-0000	
1	1	Nacelle complete	648-10-0000	
Pos. No.	Description		Drawing / Specification	Material
WTN 648	 Wind Technik Nord		Weight: N/V	Material:
	Name: Main view WTN 648 - 50m		Drawing No.: 648-00-1000	Scale: 1:200 at A2
	Date: 12.03.2010	Name: Braukmann	Production tolerance: DIN ISO 2768-T1 m (mittel)	Correction: Date: Name: Page: 1 of 1
	Check: _____			
According to the law we reserve the right of property of the present drawing, which cannot be printed or transmitted without our written authorization.				

Location Plan

CENTRE COORDINATES: 538156, 281353

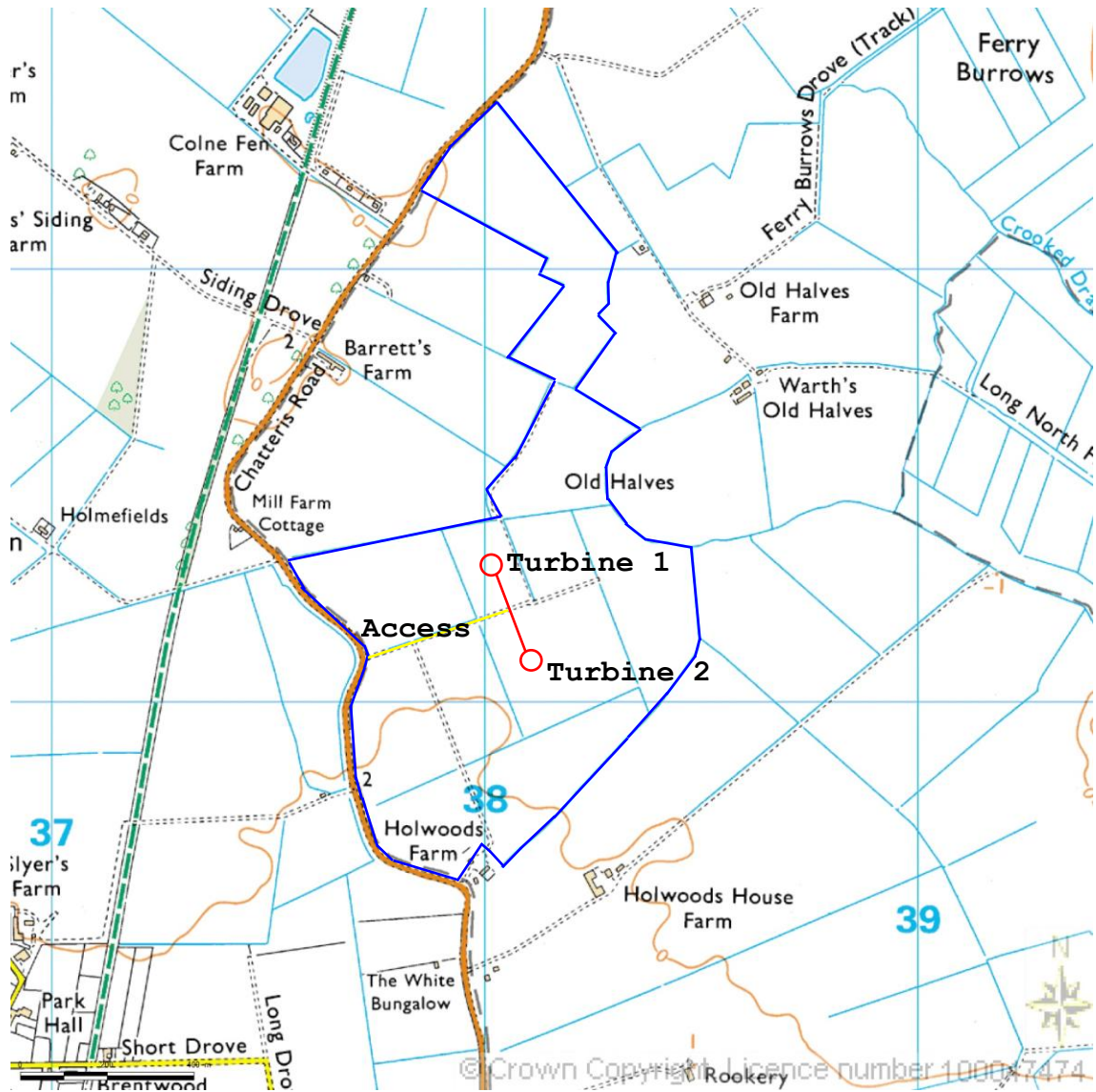

TURBINE 1: X 538156, Y281353; TURBINE 2: X 538201, Y 281122

**LAND SOUTH WEST OF HALVES FARM, CHATTERIS ROAD, SOMERSHAM,
CAMBRIDGESHIRE**



Supplied by Streetwise Maps Ltd
www.streetwise.net
Licence No: 100047474
30/04/2012 09:40:37

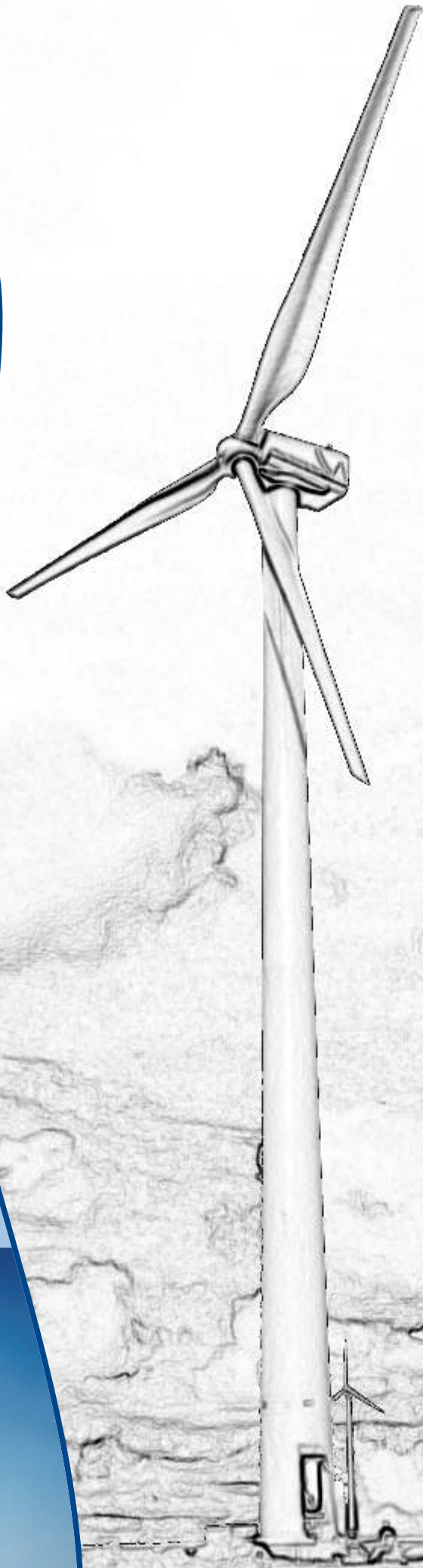

WTN 500



CERTIFIED WINDTECHNOLOGY

General

The wind power plant WTN 500 is a pitch-controlled turbine with completely variable speed for operation parallel to the public grid. The rated output of the plant is 500 kilowatt; the rotor diameter is **48 meters**. The rotor has three blades and is arranged in upwind position to the tower. Yawing into the wind is achieved by two electrically driven yaw systems. For the tower you can choose between a **50 m tubular tower** and a **65 m lattice tower**.

The mechanical concept of the nacelle is based on a three-point-fixing of the main bearing together with the main gear unit and a two-generator system.

The WTN 500 operates with variable speed. The rated power of both asynchronous generators comes to 280 kilowatts each. Two frequency converters are installed to feed the electrical power to the grid.

The primary brake and safety system is the independent pitch of each rotor blade. Each blade is driven by help of a gear-motor-unit to the desired pitch position. At all stops the rotor blades are pitched independently into brake position. During grid outages this is guaranteed through a spring package.

The disk brakes are used only at emergency stop or as brakes to hold the rotor for services. They are operated pneumatically. The turbine is designed corresponding to type class 2A according to IEC TC 88.

Rotor

The rotor consists of three low noise and power optimized rotor blades with a self-supporting structure of epoxy resin, reinforced by glass fibre. Through the application of glass fibre fabric, a high strength is obtained. The lightning protection is integrated in the blade.

Pitch system

Each rotor blade has its own pitch drive with a maintenance-free servomotor, a gear unit and a spring storage unit. To reach the best output, the rotor blades work independently, but altogether they are synchronized electronically. In case of grid failures a spring unit serves as energy storage for the movement of the rotor blade back to the sail position. It is connected directly to the blade bearing and drives the rotor blade in the neutral sail position within a few seconds.



Drive unit

The rotor blades are connected with a two-rowed four-point contact bearing to the casted hub, that is optimized by FEM-analysis. Through the forged flanged shaft the rotation is transmitted to the main gear. The three-point-fixing of the main drive unit takes up all axial forces in the main bearing at the front of the flanged shaft, while the radial forces are transmitted to the nacelle frame by the bearings mounted to both sides of the main gear. The connection between the main gearing and the nacelle frame is realized by bushings. Their rubber elements damp the sound of the gearbox from the frame and guarantee a quiet and noiseless operation of the whole wind turbine.

Electrical system

The electrical energy is produced by two squirrel cage induction generators with a rated output of 280 kW each. By means of a flexible and isolated coupling they are connected to the shaft of the gearbox.

For each generator a frequency converter is installed, which allows an in-

SECURE WINDTECHNOLOGY

dependently energy delivery. Depending on the wind speed one or both converters will be in operation. The frequency converter reaches high grid quality with the integrated filters to eliminate interferences like harmonics and there is no extra compensation required for reactive power.

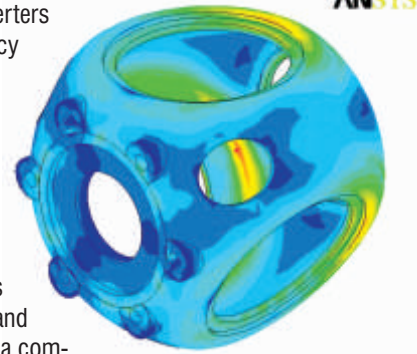

Control system

An extensive sensor technology is installed to control all functional and safety procedures permanently by a computer-aided management system. The interaction of pitch and frequency converter of the variable speed controlled plant guarantees the highest utilization from the wind energy.

A control unit suited inside the tower respectively next to it allows all operations, protected by passwords, from downstairs. Via modem or ISDN it is also possible to control the operations by a remote supervision.

Safety concept

The primary brake and safety system is the independent blade pitch of the rotor. The pitch control does not only optimize the power output; it limits also the rated power to avoid undesirable overloads. Any information to the control system, which influences the safety of the plant, is answered by an immediate reaction of the pitch control.

In case of grid failures, the pre-stressed spring packages cause an automatic pitch of the blades into the safe sail position. The rotor remains without brakes and thereby relieves the driving unit. A disk brake on the high-speed shaft of the gearbox is operated pneumatically when the emergency switch is engaged. It can also be operated by a handle as a brake system for maintenance.

Service life

All components of the WTN 500 are designed for a technical service life of 20 years. The installation of standardized, tested components and the operating system, controlled by torque, guarantee the safe function and optimum energy output in the long run of lifetime.

Calculated powercurve

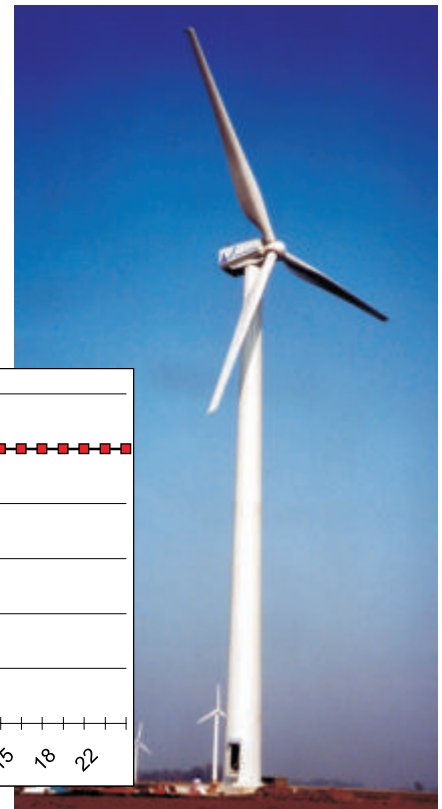
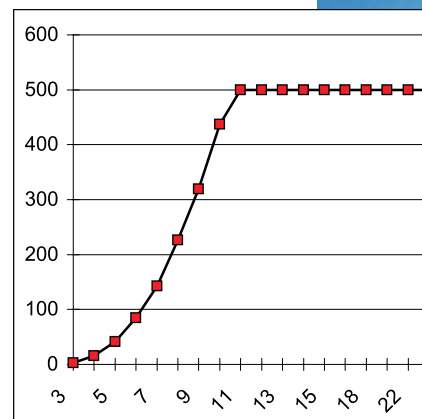

TECHNICAL DATA

WTN 500 - 50 m hub height (tubular tower)

WTN 500 - 65 m hub height (lattice tower)

1. General	
Nominal Output:	500 kW
Rotor shaft arrangement:	horizontal
Effect limitation:	pitch
Mode of operation:	grid connected
Hub height:	50 m (tubular) / 65 m (lattice)
Survival windspeed:	59,5 m/s (50 m) - 52,5 m/s (65 m)
Calculated lifetime:	20 years

2. Power data (10 min-mean windspeed in hub height)	
Cut in windspeed:	3 m/s
Rated windspeed:	12 m/s
Power at 10 m/s:	437 kW
Cut out windspeed:	25 m/s
Max. shaft power:	660 kW
Specific output:	276 W/m ²

3. Rotor	
Diameter:	48 m
Swept area:	1.810 m ²
Number of blades:	3
Kind of hub:	rigid
Arrangement of rotor:	upwind
rotor speed range:	10 - 30 rpm
Lambda:	5,5
Pitch angle:	2 - 88°
Conus angle:	0 °
Nacelle angle:	4 °

4. Blade	
Type:	WTN 23,1 - Profile: FX77/79xxx
Material:	GfK / EP
Lenght of blade:	23,1 m
Weight:	2.100 kg

5. Gear	
Type:	helical spur gear
Ratio:	1 : 50,3
Nominal torque:	190 kNm

6. Yaw system	
Kind (active/passive):	active
Actuation:	electrical
Yaw speed:	0,5 ° / s
Absorbation system:	motorbrake

7. Generator	
Quantity:	2 units
Type:	asynchronous, squirrel-cage
Rated output:	280 kW
Rated speed:	1.500 rpm
Voltage:	690 V
Frequency:	50 Hz
Nominal slip:	0,9 %
Protection:	IP 54
Grid connection:	full size inverter

8. Tower (material: steel)	
Kind & lenght	tubular 48,5 m / lattice 63,5
Safety ladder:	with climbing support

9. Control system	
Power regulation:	pitch, electrical activation
Operating system:	WP 3100
Remote control system:	yes, via telephone line
Automatically start:	after loss of grid and after cut out wind

10. Brakes	
Aerodynamic brake:	pitch system (3x)
-Activation:	electrical
Mechanical brakes:	yes
- Arrangement:	behind gearbox
- Brake type:	disc brake
- Activation:	mechanical

11. Masses	
Rotor assembly:	11.800 kg
Nacelle assembly:	24.500 kg
Tower:	54.000 kg / 61.500 kg
Total:	90.500 kg / 98.000 kg

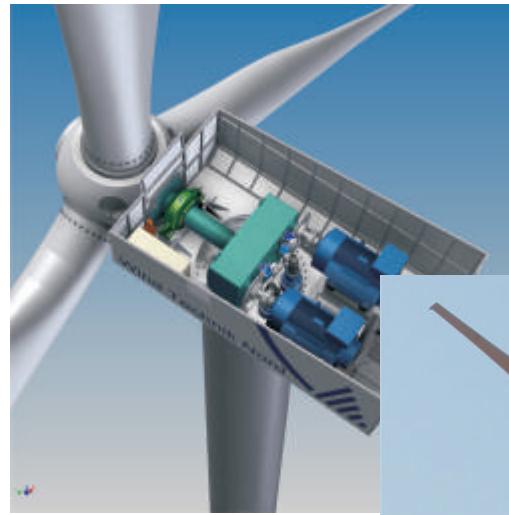

WTN 500/65

WTN 500/50

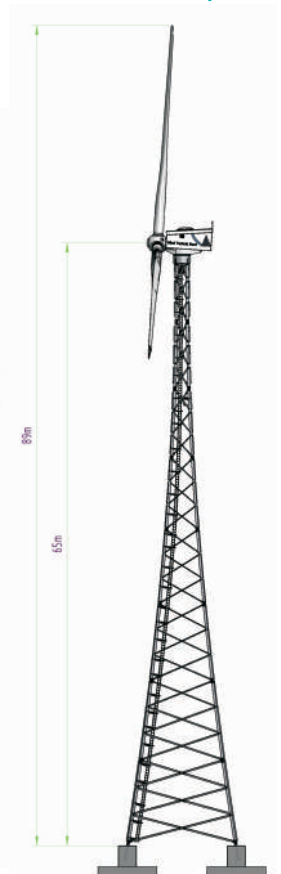
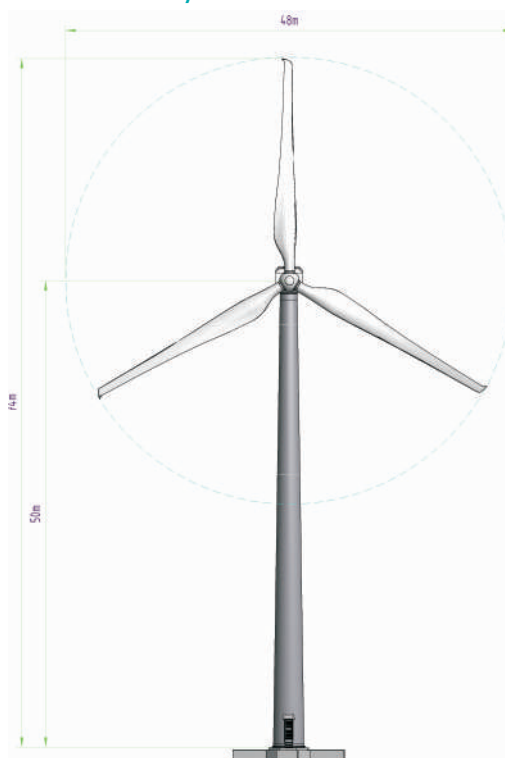



Enger Straße 13
D-25917 Enge-Sande

Tel.: +49 46 62-69 80 00
Fax: +49 46 62-69 80 09
Mobil: +49 170-327 14 14

E-Mail: info@windtechniknord.de

www.windtechniknord.de

